

# VESSEL DATA SHEET

Design Parameters	
Pressure, Max. at Inlet	740 psi
Temperature	100 F
Corrosion Allow.	0.00"
Code Standard	ASME Sect. VIII, Div. 1
Stamped?	No

Operating Parameters	
Pressure, Max.	740 psi
Temperature	100 F
Typical Flow Rate	420,000 scfh @ 740 psi
Gas Specific Gravity	0.60

Vessel Testing	
Hydrotest Pressure	1110 psi
Pneumatic Test Pressure	N/A
Radiograph	None
Magnetic Particle	None
Dye Penetrant	None

Filtration Performance	
Filter Element P/N	2385K140
Type of Filter Media	Polyester/Cellulose Blend
Retention Rating	10 micron
Efficiency of Retention	99.9%
No. of Elements	1
Design Clean Press. Drop	Less than 1.0 psid
Changeout Press. Drop	At 9 psid

Closure Specifications	
Type	Blind Flange
Gasket Type	P/N 6-300
Type of Lifting Assistance	Lifting Lug/Handle

Internal Finish	
Sandblast	Light
Oil Coat	None
Glyptol Coat	None

External Finish	
Sandblast	SP-10 Commercial
Finish Coat	(2) Coats Grey Enamel Direct-to-Metal Finish

Schedule of Openings						
Service	See Dwg.	Qty.	Size	Rating	Type	
Inlet	A	1	2"	300# ANSI	Flange	
Outlet	B	1	2"	300# ANSI	Flange	
Drain	C	1	1/2"		Coupling	
Vent	D	1	1/2"		Coupling	
Press. Tap	E	1	1/4"		Coupling	
Press. Tap	F	1	1/4"		Coupling	

Materials of Construction			
			Thickness
Shell	SA53B		0.280"
Bottom Head	SA234WPB		0.280"
Closure Head	SA105	ANSI 300#	Flange
In/Out Piping	SA53B		0.218"
Flanges	SA105	ANSI 300#	RF Fig
Couplings	SA105		3000#
Closure Gasket	Fiber Flat Gasket		
Closure Pipe	N/A		
Legs	N/A		
Ring Base	N/A		

Shipping Information		
Total Weight	200#	

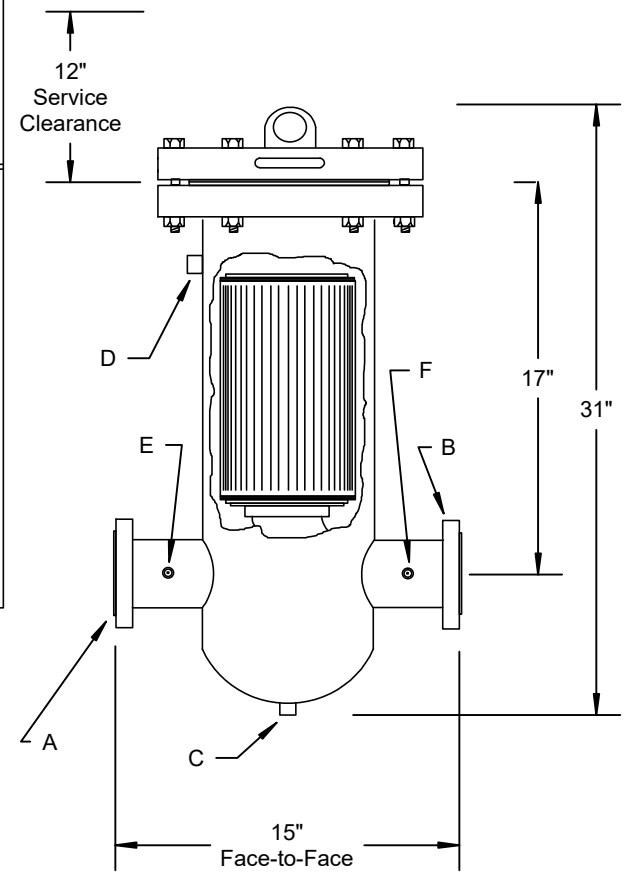

Optional Threaded  
Quick Opening  
Kimray Knock-Off  
Closure

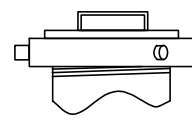

**FilterFab**  
MANUFACTURING CORPORATION

Model F2-740F Gas Line Filter