

# VESSEL DATA SHEET

Design Parameters	
Pressure, Max. at Inlet	1,480 psi
Temperature	100 F
Corrosion Allow.	0.00"
Code Standard	ASME Sect. VIII, Div. 1
Stamped?	No

Operating Parameters	
Pressure, Max.	1,480 psi
Temperature	100 F
Typical Flow Rate	17.0 MMscfh @ 1,400 psi
Gas Specific Gravity	0.60

Vessel Testing	
Hydrotest Pressure	2,220 psi
Pneumatic Test Pressure	N/A
Radiograph	None
Magnetic Particle	None
Dye Penetrant	None

Filtration Performance	
Filter Element P/N	(2) 2070K5
Type of Filter Media	Polyester
Retention Rating	10 micron
Efficiency of Retention	99.9%
No. of Elements	1
Design Clean Press. Drop	Less than 1.0 psid
Changeout Press. Drop	At 9 psid

Closure Specifications	
Type	Blind Flange
Gasket Type	P/N 20-600SW
Type of Lifting Assistance	Davit Arm, Hydraulic

Internal Finish	
Sandblast	Light
Oil Coat	None
Glyptol Coat	None

External Finish	
Sandblast	SP-10 Commercial
Finish Coat	(2) Coats Grey Enamel Direct-to-Metal Finish

Schedule of Openings						
Service	See Dwg.	Qty.	Size	Rating	Type	
Inlet	A	1	10"	600# ANSI	Flange	
Outlet	B	1	10"	600# ANSI	Flange	
Drain	C	1	1"		Coupling	
Vent	D	1	1"		Coupling	
Press. Tap	E	1	1/4"		Coupling	
Press. Tap	F	1	1/4"		Coupling	

Materials of Construction		
		Thickness
Shell	SA106B	1.031"
Bottom Head	SA234WPB	1.031"
Closure Head	SA105	ANSI 600# Flange
In/Out Piping	SA106B	0.719"
Flanges	SA105	ANSI 600# RF Fig
Couplings	SA105	3000#
Closure Gasket	Spiral Wound Gasket	
Closure Pipe	N/A	
Legs	N/A	
Ring Base	N/A	

Shipping Information		
Total Weight	4,600#	

Optional Threaded Quick Opening Modco Closure

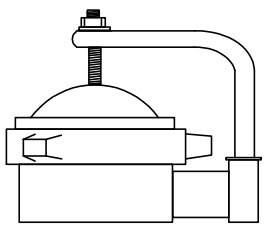

Optional Angle Support Legs

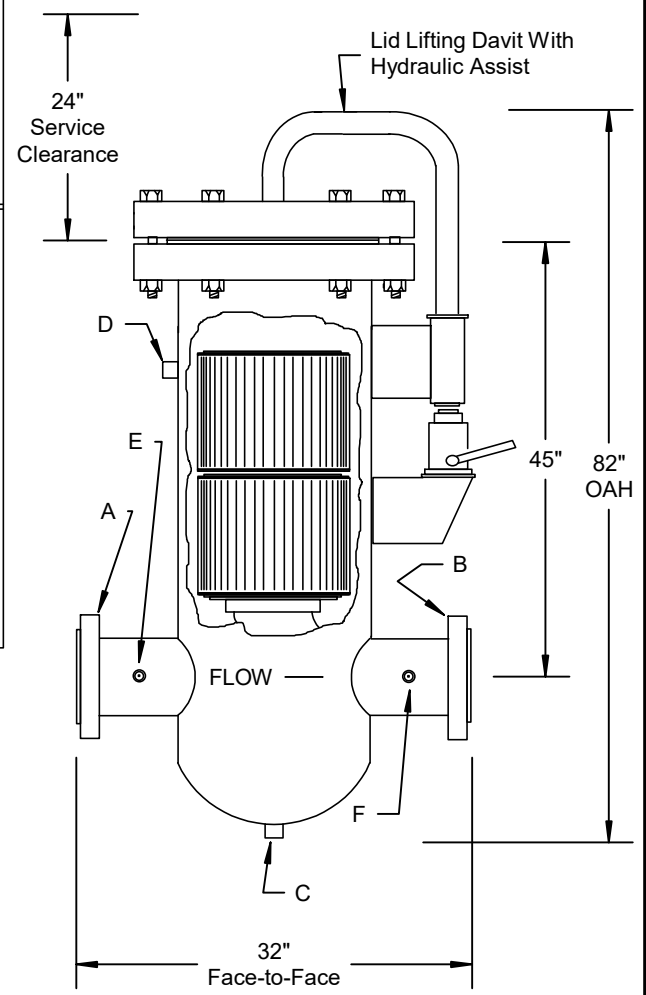
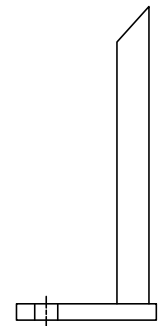

**FilterFab**  
MANUFACTURING CORPORATION

Model F10-1480F Gas Line Filter